



# 11<sup>th</sup> Unmanned Systems Canada 2019 Student UAS Competition

## Concept of Operations (CONOPS) and Rules

### Version

1. This is Version 3 of the document, released on 3 November 2018. It is subject to change at the discretion of the Competition Committee.
2. At the end of the document are questions posed by student teams, with appropriate responses. Where required, the CONOPS has been modified as a result of the questions.

### Foreword

3. This document provides details regarding a “made in Canada” Simulated<sup>1</sup> BVLOS UAS Student Competition. The purpose of the competition is to promote and develop Canadian expertise and experience in unmanned systems technologies at the university and college levels. Small unmanned vehicles are complex systems requiring a well planned and executed design and rehearsed operational approach. In addition, safety considerations are important factors in this competition as in any other vehicle design project.
4. The mission for the 2019 competition is to provide support to a utility company after a wind storm, including surveying a field of solar panels (solar farm) with the UAS not in operator line of sight, identifying significant changes to the solar field, locating any major damage to individual solar panels, and placing inspection markers adjacent to critical cells on damaged panels.

### Competition Format

5. The competition is organized in two Phases, including:
  - a. Phase 1 Technical Competition, in which teams complete a design paper describing the team approach and plans, due 13 January 2019 at 5pm EST; and

1. \_\_\_\_\_

<sup>1</sup> The scenario involves BVLOS tasks for the competition teams, in that the pilot and flight team will not be able to see the UAS during a portion of the flight. However, from the standpoint of Canadian regulations, the entire flight of the UAS will be within sight of observers who are able to order ‘kill’ of the UAS in accordance with Conops procedures.

- b. Phase 2 Airborne Competition, in which teams present their teams and conduct flying tasks as described later in this document. Phase 2 takes place 3-5 May 2019 at Alma UAS Centre of Excellence, Quebec.
6. All teams must complete Phase 1 to be eligible to participate in Phase 2. There will be separate prizes for each Phase. The competition schedule is in Para 22.

## Eligibility

### General

7. All competitors must be full-time students at a Canadian college or university for Fall 2018 or Winter 2019.

### Team Composition

8. Teams may be organized internally at the discretion of their respective members, and may include graduate and undergraduate students. It is suggested that students from multiple years be encouraged to participate. Joint teams consisting of students from more than one institution are also permitted. For example, a joint university-college team is allowed.
9. The Competition is not open to commercial entities.
10. NOTE: In previous years it was permissible to have a pilot who was neither a student nor a member of the team. **THIS IS NO LONGER PERMISSIBLE.** One or more of the five flight line members of the student team must pilot all team aircraft.

### Team Size

11. There is no maximum or minimum team size, and no maximum crew size in the preparation area; however, the flight-line crew is limited to 5 people. Availability of accommodation may limit the number of team members attending the competition.

### Number of Teams

12. There is no restriction on the number of teams from any given institution; however, no individual student may be on more than one team, and submitted projects from different teams must be substantially different. Teams will be accepted at the discretion of the Judges.

## Applications and Registration

13. Teams should send an email indicate their interest to **competition@unmannedsystems.ca**, and complete the online registration on **www.unmannedsystems.ca** including paying the team registration fee of \$500. Registration is non-refundable. Once fully registered, teams will have access to more information from USC. **Registration deadline is 9 November 2018 at 5pm EST.**
14. Student teams are encouraged to seek sponsorship opportunities for their project. There is no restriction on the level or type of sponsorship that may be provided. Teams are responsible for covering their own costs including travel to and during the demonstration phase. Accommodations and

meals will be provided to registered team members at a cost of \$250 per member. This payment is due by 5 April 2019 and is not refundable. Liability insurance for authorized UAS flights at the competition on competition dates is required to obtain an SFOC and is the responsibility of each team.

15. The competition ends at 2200 hrs after the awards banquet on Sunday night. Departing immediately following the banquet is NOT endorsed by USC. Plan to leave on Monday to ensure safe driving home. Ensure that all drivers on a rental car have a full driver's license in good standing. Your safety IS our concern.

## Scenario

16. Solar power is the fastest growing source of new energy, and it is predicted that its capacity growth will be higher than any other renewable energy by 2022. In Canada, photovoltaic cells have been primarily used as standalone units powering off-grid remote homes, navigational devices, pipeline monitoring systems and telecommunication equipment. Ontario was one of the first global leaders for solar energy projects with their Feed-in tariff (FIT) that was implemented in 2009 and housed one of the largest solar farms (fields of solar panels) in the world until it was surpassed by larger farms in China and India.
17. Solar farms are required by law to be scanned annually with an infrared camera to inspect their efficiency, although it is recommended that more regular inspections be completed to maintain the solar farm at peak performance and minimize potential power loss. Due to the large size of these solar farms, which can range from 1 to 100 acres or more, UAS are being deployed to provide accurate imagery and greater accuracy than possible with inspectors using handheld cameras.
18. A UAS with an infrared camera can quickly identify a failed cell or diode because it shows when a cell is not generating electricity. Panels can also fail for reasons other than faulty cells. For example, dirt can build-up on the surface of the panel, inclement weather can damage the cells, and even small debris can create micro-scratches on the surface which deflects sunlight.
19. This competition will focus on the development of a system capable of providing timely information concerning the damage inflicted to a solar farm after a wind storm, as well as the prioritization of repair.
20. Your report will be judged on the following results:
  - a. Ability to survey the existing solar farm;
  - b. Identification of significant changes to the site (i.e. tree blew down in the site);
  - c. Identification of damage to solar panels (i.e. intensity of IR emission);
  - d. Analysis of results and prioritization of the three most critical panels;
  - e. Detailed inspection of the three most damaged panels; and
  - f. Placement of markers on these panels to indicate that they need repair.
21. In addition, your team's UAS, including the air vehicle(s), associated ground systems, and marker placement devices, will be assessed for technological readiness, user characteristics, and performance.

## Schedule

22. The schedule for Phase 2 in Southport will be as follows:

- a. Thursday evening – teams give their oral presentation to the Chief Judge on a USB stick, in PowerPoint 2013 format;
- b. Friday morning – teams conduct an 8-minute scored oral presentation to present their team and their plan for conducting the Tasks;
- c. Friday afternoon – teams conduct Flight Readiness Review to demonstrate compliance with aircraft safety requirements as detailed in this Conops. Note that depending on forecast weather for the weekend, operational tasks may begin on Friday afternoon, or there may be practice flight time allocated;
- d. Friday afternoon or evening – teams will be briefed by an employee of the utility company about the survey, inspection, and marking Tasks. Technical requirements and UAS capabilities will be according to Paras 27, 34, and 41. Teams may ask any questions they wish to clarify the requirements for the Tasks;
- e. Saturday – teams conduct Simulated BVLOS Survey Task; and
- f. Sunday – teams conduct Simulated BVLOS Detailed Inspection and Marking Tasks.

23. Mission requirements for the three Tasks are contained in the following paragraphs.

## Mission Requirements

24. The details of the three Tasks will be presented to the teams in a briefing by an employee of the utility company. UAS which meet the mission requirements in the following paragraphs will be able to accomplish all the Tasks.
25. The intention of this competition is that teams have multiple opportunities to gain points, to make strategic decisions about how to accomplish the Tasks, and, if necessary, to decide which sub-tasks to discard or emphasize to maximize points, based on the capabilities of your systems. Teams may enter the competition and choose in advance to not attempt any given Task(s); clearly you would be forgoing the points for any missing Task(s). In the spirit of innovation and challenge, we encourage teams to attempt all Tasks in the competition.
26. There will be one flight window for each team on each day of the competition. Within each flight window, you may fly your UAS(s) as many times as you wish to attempt to achieve the requirements of the relevant Tasks. However, you may not attempt Task 2 and 3 in the first flight window, or redo Task 1 in the second window.

### Task 1 – SIMULATED BVLOS Solar Farm Survey

27. The UAS and operator(s) must be able to meet the following requirements:

- a. Fly from the launch location to a solar farm location shown on the map provided by the utility company at the briefing. The solar farm will not be further than 1 km from launch;

- b. Conduct a survey of the solar farm. The area of the farm is no larger than 300 m x 300 m, portions or all of which will not be in line of sight;
- c. Provide the locations of damaged solar panels. In the solar field there will be a minimum of 5 and a maximum of 15 damaged panels. Damage is indicated by IR emitters, as further described in Para 30.
- d. Identify changes from the provided map of any significant features (eg, trees knocked down, changes to structures, vehicles or other items, etc). The map will be provided to teams in hard copy and digital form (JPEG);
- e. Complete the survey in the shortest possible amount of time; and
- f. Provide an amended version of the provided solar field map which includes:
  - i. Identification of damaged solar panels and degree/size of damage (i.e. IR emission, pattern and location).
  - ii. Indication of significant changes to map features (i.e. any changes other than the damaged panels).
  - iii. Appropriate annotations.

28. The amended map may use images, plan-view mapping, 3D pixels, or any other means. The amended map must be presented to the judges in a format viewable by a standard laptop (download of a 'reader' application is acceptable) within one hour of completion of the first flight window. To be clear, the submission must include the original map overlaid with the amended and additional information.

29. Teams will be scored on the following, with further scoring details in Para 78:

- a. Identification of significant changes to map features;
- b. Correct identification of the damaged solar panels:
  - i. Correct number and location of damaged panels;
  - ii. Degree<sup>2</sup> of damage as indicated by size of IR emission.
- c. Prioritization of the three most critical panels in need of immediate repair. The methodology for determining the prioritization of panels will be revealed in a briefing, but will involve observing the degree of damage, location of damage, and pattern of damage; and
- d. Time to complete the survey.

30. Thermal imaging of solar farms can result in the identification of several faults. The shape and location of hot spots can indicate the type of fault. In this competition, a hot spot will be simulated by an IR LED array. The shape, size and location of the hot spots will determine the priority and significance of damage as per the methodology given in the briefing. Teams must have the ability to

1. \_\_\_\_\_

<sup>2</sup> Degree is defined as the % of area affected by the IR emission. Further details will be provided in the utility company briefing.

recognize whether the IR LED is active or not. An example of what teams can expect for IR emission is in Para 31.

31. The IR illuminator photos were taken from an altitude of approximately 80 m by a previous competing team. It is not known what camera was used or the resolution of its sensor. It is quite apparent from the active IR photos that the IR illuminator triads are lit. The lack of glow from the inactive IR illuminators is also quite distinctive. Teams will be provided with the wavelength range of the IR emitter in the near future.

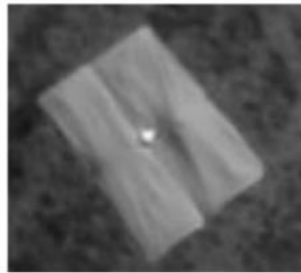

Active Emitter

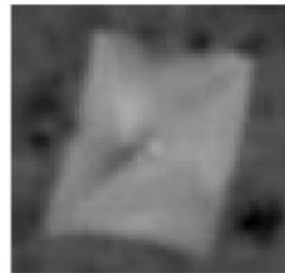

Inactive Emitter

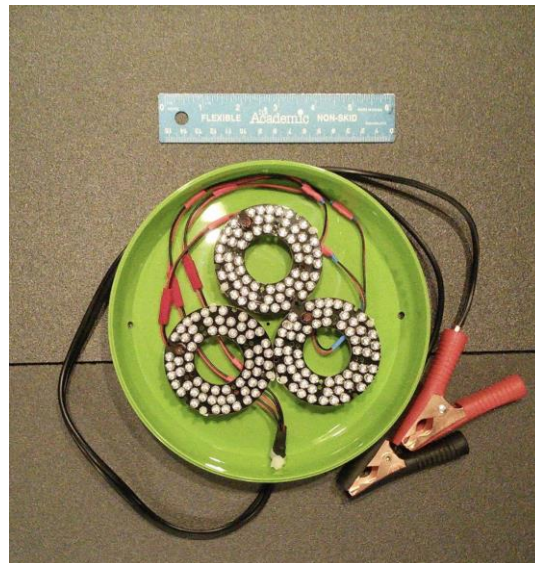

Example IR Emitter Triad (940nm)

## Task 2 – Detailed Inspection

32. The three solar panels identified in Task 1 requiring immediate repair will be at varying angles relative to the ground plane (between 10-30 degrees), each having one damage area. The panels will be supported by frames off the ground. If the panels were not identified by the team in Task 1, the judges will provide the three solar panel locations at the conclusion of the previous day's flights. Note that the damage areas described in Tasks 2 and 3 will no longer use IR emitters to simulate the damage, see Para 34 for further details.
33. Before repair technicians are deployed, a detailed inspection of the damaged areas is required so that the correct tools and supplies are compiled.

34. The UAS must be able to meet the following requirements:

- a. Fly from the launch location to the damaged solar panels (BVLOS);
- b. Find the damage area on each critical solar panel and take detailed visual images of the damage (i.e. should be capable of reading 16 pt. font). Within the damage location, there will be clues as to what type of damage has occurred at the particular location. These clues will be clear if an image of sufficient resolution is taken; and
- c. Determine the major dimensional details of the damage area and provide a visual representation of the findings. The area could be any of the following shapes: circle, square, rectangle, trapezoid, or parallelogram. The damage area will be clearly visible (painted dark or visible color). The visual representation could be a drawing, jpeg, etc.

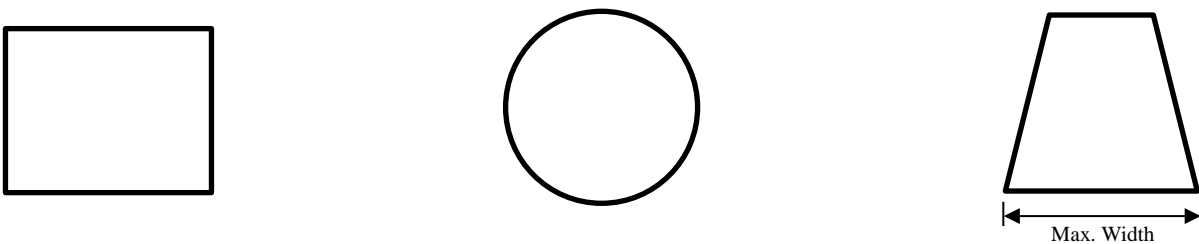

Figure 1 - Possible Damage Layout

35. Teams will be scored on the following, with further scoring details in Para 79:

- a. Identification of the type of damage of each damaged solar panel based on the clues provided; and
- b. Correctness of the visual representation of the damage areas, including accuracy of the dimensions, colour of the damage area, etc.

### Task 3 – Damage Area Marking

36. The utility company has designed a marker to be placed at the damage location to indicate a repair is needed. This allows the repair process to run more smoothly and efficiently when workers start repairs on the solar farm. The three damage areas identified in Task 2 need to be marked. The solar panel angles (varying from 10 to 30 degrees) will be given to teams following the completion of the first flight window for Task 1.
37. The engineering drawing of the marker, including the exact dimensions and material is provided at the end of this document. The markers weigh approximately 8 grams each.

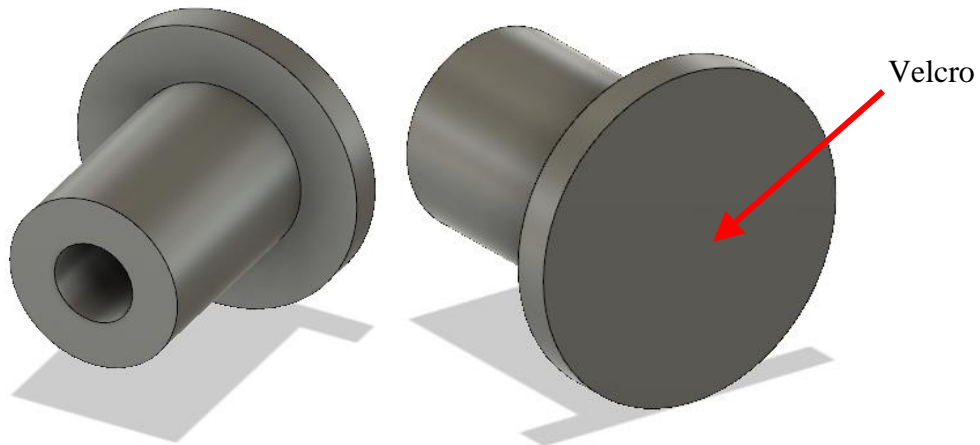

Figure 2 – Sample Inspection Marker

38. Teams will be provided with three markers, which will include the required Velcro – the soft (loop) side will be on the target panel, and the hook side will be on the markers. The brand of Velcro may be revealed later, but this won't be a determining factor in if your solution works!
39. The three markers can be placed while completing Task 2, or once Task 2 is complete. The three provided markers must be transported on a single flight to be placed on the targets; no other markers may be used. The markers may not have anything attached to them, must be attached to the targets using the included Velcro only, and no other objects may be left on the solar panel or ground. To be scored, the markers must be oriented with the Velcro side latched onto the target.
40. The UAS may not land on the solar panels. Incidental contact between UAS and panel will not be penalized; however, the methodology of locating and placing the markers may not require contact.
41. The UAS must be able to meet the following requirements:
  - a. Fly from the launch location to the damaged solar panels (BVLOS), unless the markers will be placed during Task 2.
  - b. Place a marker within 30 cm of any edge of each of the three damaged locations (area around will be covered in Velcro to help attach marker). All three markers must be placed within one flight, and the UAS may not land on the solar panel.
  - c. Safely return the UAS without the three markers to the launch location. To receive full points, the UAS must return with NO markers on board, regardless of the success (or lack thereof) of placing the markers on the panels.
42. Teams will be scored on the following, with further scoring details in Para 79:
  - a. Delivery of three markers; and
  - b. Accuracy of marker delivery relative to the damage areas.
43. A bonus will be available if the team is able to return to the launch location, after successfully delivering the three markers.



## UAS Design Constraints

44. The following UAS design restrictions will be verified prior to being allowed to fly:
- a. Maximum take-off weight of 10 kg (payload and batteries included);
  - b. Only internal combustion engines and electric propulsion (solar cells, batteries or fuel cell). Micro gas turbines and pulsejets are not permitted. Any other form of propulsion is acceptable if deemed safe in the Phase I Technical Competition by the judges;
  - c. UAS must have a flight termination system to safely end flight as described in Para 53;
  - d. All UAS must be brightly colored to be visible from the ground and to be easily located in the event of a crash. Safety orange day glow paint is recommended. Vehicles must also clearly display the team name;
  - e. Data links can be by radio, infrared, acoustic, or other means so long as no tethers are employed. UAS may operate autonomously, semi-autonomously, or under manual control at the discretion of the teams;
  - f. Multiple aircraft can be used, if approved by the Transport Canada SFOC for the competition, if there is one person who has full control of each aircraft at all times. In other words, one person cannot be controlling multiple aircraft at the same time;
  - g. Radio frequency usage in Canada is defined by ISED. If a licensed band is used, the license must be obtained and provided to judges before being allowed to fly. Because all transmitters will have to be OFF on the entire airport property during the competition, except for the team flying, it is highly recommended that teams develop an alternate (wired) method to pre-flight and test their system. Teams may assume that high-speed internet will NOT be available on the field; and
  - h. This is a UAS design competition. Using completely off the shelf UAS (example DJI Phantom) is not allowed.

## Flight Operations

### Flight Schedule

45. Teams may expect to receive two flight windows for the three Tasks, each of which will be about 30-45 minutes. The actual amount of time allowed to the teams for flight will be announced prior to the start of the competition flights; the allocated time is subject to change due to uncontrollable factors.
46. The schedule will be determined by random lottery for the team presentations and two flights; the schedule will be passed to the teams on arrival at the Competition.
47. Teams may be (and are encouraged to be!) setting up while another team is flying.

## Flight Teams

48. Teams will designate a “flight crew” consisting of maximum 5 team members plus a safety person at the Simulated BVLOS location. Only the flight crew may be present while the team is on the flight deck (pre-flight and flight).
49. All Pilot(s) In Command must remain at the launch point for all flights, and the focus of a PIC’s attention must be on the aircraft in flight.
50. Figure 3 shows the overall SFOC flight limits for the Tasks – detailed areas for the Simulated BVLOS survey and evidence gathering Tasks will be given in the briefing by the utility company. Maximum altitude will depend on the SFOC but should be around 1000ft AGL.
51. Teams will be given the GPS coordinates of the area of interest on arrival in Alma.
52. After their last flight of the competition, teams have 90 minutes to give their report to the judges. A USB stick will be provided to each team, and reports must be in PDF format. The USB stick must be returned to the judges at the allotted time and the contents will be judged according to the report criteria.



Figure 3 - Alma Flight Area

## Safety

53. All UASs must be equipped with a safety flight termination system that can be activated either automatically or remotely (kill switch). For fixed wing, this could consist of using a parachute, or shutting down the engine and performing aerodynamic termination, which corresponds to full aileron, elevator up, full rudder and no motor. Circling down is not acceptable. For rotary wing, a quick vertical descent of minimum 2m/s and touchdown must be performed. The flight termination mechanism must be operational at all times. **If the flight termination mechanism is not working, the aircraft must terminate the flight itself automatically and rapidly.** In other words, if unable to kill the aircraft, the aircraft should already have killed itself. Under no possible situation should the UAS be in flight and the crew unable to activate a kill mechanism. Aircraft must be in termination mode within 10 second of the termination function being activated. The flight termination mechanism will be validated during the Flight Readiness Review (FRR) check.

54. Teams may turn on transmitters at the start of their flight window. Teams must turn their transmitters OFF after their flight window has elapsed. NO transmissions of any sort are allowed outside the flight window, including Wi-Fi hotspots and the like.
55. During flight, the GCS must always show the aircraft, the SFOC approved area, and the competition flight area.
56. Rehearsals are not permitted unless specifically authorized by the judges.
57. If the aircraft leaves the flight boundaries, the operator will be asked to bring it back within the boundary. If the operator is unable to do so, he will be asked to activate the kill mechanism.
58. All anomalies with respect to the GPS, Datalink, RC and flight boundaries must be reported to the Air Program Director.
59. Teams must have an electrical or mechanical way of preventing propellers from accidentally spinning when aircraft is not in takeoff position and ready for takeoff (i.e. when working on the aircraft).
60. A video proof of previous successful flight of the aircraft in the configuration planned for the competition must be presented to judges by 13 April 2019. It must show at least the following elements:
  - a. Takeoff;
  - b. Fly by, circle, and (if applicable) hover to demonstrate the stability of the UAS;
  - c. Approach; and
  - d. Full-stop landing.

## Special Operations Flight Certificate

61. Each team is required to obtain an SFOC to cover flight testing of their UAS at their local test location. Each team is also required to obtain an SFOC for flying at the competition. Each team's individual SFOC will be required to be allowed to fly at the competition and will have to be presented to the judges. Transport Canada may require around 4 months to approve an SFOC; therefore, it is highly recommended that teams submit their SFOC application to Transport Canada in the fall and do follow up with their local inspector to ensure they received the application and are processing it.
62. Note that although some Tasks to be conducted during the competition are 'BVLOS' from the standpoint of the competition team, the overall conduct of the flying operation is not. Judges, a safety spotter, and other personnel will have eyes on the vehicles at all times, and the required termination procedure will ensure the vehicle cannot pose a hazard outside the immediate area. As such, SFOCs are NOT to indicate 'BVLOS' operation.
63. Transport Canada UAS information website: [tc.gc.ca/safetyfirst](http://tc.gc.ca/safetyfirst).

## Evaluation Criteria

64. Phase 1 and 2 are scored and prizes awarded separately.

65. Phase 2 has a total possible score of 200 points (210 including bonus). The individual criteria are detailed in the following paragraphs, and a summary of the Phase 2 scoring is shown in Table 6.

**Phase 1 Design Paper – Due 13 January 2019 at 5pm EST.**

- 66. The Phase 1 Technical Competition will consist of a written proposal submitted by each team describing the technical details of their proposed competition design. All teams must complete the Phase I Technical Competition in order to be eligible to participate in the Phase II Airborne Competition.
- 67. Each design paper must be accompanied by a draft SFOC Application or an SFOC for local flight test.
- 68. The design paper will be evaluated according to the criteria in Figure 4, weighted as shown. Each criterion is scored either 0, 4, 7, or 10, for a maximum possible score of 100 points.

<b>DESIGN PAPER</b>	<b>Score</b>	<b>Notes</b>
Days Late		
<b>Overall Presentation</b>	<b>Weight: 15</b>	
Grammar/Spelling Structure/Organization Use of Figures/Charts/Tables References Provided/Correct		
<b>Technical Description of UAS</b>	<b>Weight: 50</b>	
Analysis of Alternate Solutions UAS Features and Capabilities Communications and Control BVLOS Strategy Survey Methodology Detailed Inspection Methodology Marker Placement Methodology System Level Testing		
<b>Technical Innovation and Novelty</b>	<b>Weight: 10</b>	
Novel Approach to Mission Requirements Emphasizes Novel Elements		
<b>Safety and Risk Management</b>	<b>Weight: 15</b>	
Description of System Level Safety Issues Identify Potential Single Point Failure Modes Project Risk Management Plan		
<b>Project Management</b>	<b>Weight: 10</b>	
List of Milestones Schedule for Design/Construction/Testing Phases Project Budget		
<b>TOTAL DESIGN PAPER SCORE</b>		

Figure 4 - Design Paper Scoring Criteria

69. The following describes the expected content for each of the evaluation criteria, and provides some advice for maximizing the quality of your paper. Note that hints have been provided for content in most of the criteria – this is NOT to suggest that those specific bits of information are required, or, alternatively, that they’re sufficient. They’re just hints.

- a. Days Late – The score will be reduced by 10% for each day that the paper is late.
- b. Grammar/Spelling – There is no excuse for unreadable grammar or spelling mistakes. Get someone from the team with very good English writing skills to create or review the paper, and don't forget that Word does a pretty good job of review.
- c. Structure/Organization – Word can unfortunately not review this! Make sure the reader is presented with a clear story of what your system will do and how it will meet the competition requirements. MOST IMPORTANTLY – organize the paper according to the evaluation criteria! Judges should not have to search through the paper to determine if you've responded to a criterion.
- d. Use of Figures/Charts/Tables – Sometimes a picture is worth 1000 words. However, it needs to be large enough to be readable, have appropriate titles and labels, and be referenced from the text so the reader knows what it's trying to show.
- e. References – Provide some. Your references might be technical, operational, or...?
- f. Alternate Solutions – You will have decided on a design solution to meet the Conops requirements, both from an operational point of view and a technical one. As engineers, whether you realized it or not, you must have done an options analysis to consider other ways to approach the problem(s). Tell us about these other options, and why you chose the solution you did.
- g. UAS Features and Capabilities – What makes your vehicle special? Don't forget that 'UAS' isn't just the vehicle.
- h. Communications and Control – How is your vehicle controlled? How is your team going to communicate? Do you have automation?
- i. BVLOS Strategy – All of the tasks require Simulated BVLOS operation by the flight team. Describe how your team will control the UAS, how you'll ensure it won't hit anything, emergency procedures, how you will approach the panels, etc.
- j. Survey Methodology – Knowing that you have to complete an IR inspection and visual inspection, how do you plan on presenting your results on the amended map – legend, labels, IR map, etc.? What methods are you using to produce the amended map – using some sort of automation, hand drawing a map, etc.? This criterion applies exclusively to Task 1.
- k. Detailed Inspection Methodology – How do you plan on obtaining the required images, and accurately calculating the damage area dimensions? This criterion applies exclusively to Task 2.
- l. Marker Placement Methodology – Given the marker details, how are you going to carry it and place it at the target? How are you going to deal with the angled panels? This criterion applies exclusively to Task 3.
- m. System Level Testing – What testing will you do during development and in preparation for practice flights and scenarios? Consider the complete system – UAS, controls, cameras, delivery mechanism, etc.

- n. Novel Approach to Mission Requirements – Explain how your overall strategy for accomplishment of the three Tasks, and the individual strategies for each Task, are novel. This is NOT talking about the technologies required, which is evaluated in the next criteria.
- o. Emphasizes Novel Elements – This criteria speaks to novel technology solutions in the UAS and overall System. Think of the baseline as a manually-controlled Phantom 3 – what does your UAS have that makes it novel in the execution of the Tasks?
- p. System Level Safety Issues – Based on the scenario and on your proposed design, what safety issues do you think are important and how are you planning to address them?
- q. Single Point Failure Modes – Given your technical solution, what failure modes do you anticipate and how are you addressing them?
- r. Risk Mitigation Plan – During design and development of your system, what risks exist that may affect your ability to successfully compete in Alma, and how are you addressing the risks? Risk planning must include:
  - i. Identification of the risk
  - ii. Likelihood that the risk will happen
  - iii. Impact on the project if the risk occurs
  - iv. Measures you will take to reduce the likelihood of the risk and to mitigate its effects if it does happen
- s. Milestones – Key events in the project that signal things are progressing as planned, or not ☺.
- t. Schedule – You are mostly engineers. Give us a Gantt Chart of all significant activities in the development of your system and planning for the event.
- u. Project Budget – Don't forget to include travel and other things, in addition to purchase of 'stuff' for the UAS.

70. Phase 1 Design Papers are **due 13 January 2019 at 5pm EST**. 10% will be deducted from the score for each day late.

71. Papers are limited to **15 pages total, including any appendices, title page, table of contents, list of figures, etc.** The 15-page limit does not include the SFOC. **Pages in excess of the 15-page limit will be ignored in the scoring.**

72. The paper must be emailed to **competition@unmannedsystems.ca** in **PDF** format.

73. **Read Para 71 again.**

## Phase 2 Team Presentation

74. Teams present, to the judges and all other teams, their team and how they are going to accomplish the Tasks. This is not a technical presentation but is intended to give the client (utility company)

confidence in your team and to ‘sell’ the planned method of doing the Tasks. Presentations should include:

- a. Who your team is;
- b. The expertise of each team member;
- c. What equipment you propose to use for the work;
- d. How you propose to conduct the required Tasks; and
- e. Why the clients should put their confidence in your team.

**75. All teams are expected to attend all presentations.**

**76. Teams must present a memory stick to the Chief Judge on Thursday evening with the presentation in Microsoft Powerpoint 2013.** It is your job to find him.

77. Presentations will be scored on the criteria in Table 1. Evaluations will be conducted by audience members and the Captain of each competing team, and scores for each criteria averaged.

Table 1 - Pre-Flight Presentation Scoring

Criteria	Score
Presentation is well organized, most team members participate	4
Presentation includes all elements in Para 74	4
Slides are well-prepared, easy to read, contain appropriate media, are not overly technical	4
The presentation is clear and understandable, with limited jargon or technical terms, good speaking quality	4
The client would be convinced this is the right team for the job	4
<b>Total Possible Score</b>	<b>20</b>

### Phase 2 Task 1 – Simulated BVLOS Site Survey

78. An overview of the task requirements is in Para 27, and further details will be provided in the pre-flight briefing by the utility company. Teams will be scored on the criteria shown in Table 2:

Table 2 - BVLOS Site Survey Scoring

Criteria	Score
Amended survey map is accurate. Scoring Based on: <ul style="list-style-type: none"> <li>• Indication of damaged panels, 10 pts</li> <li>• Indication of significant changes, 10 pts</li> <li>• Correct Annotations (compass, scale, etc.), 5 pts</li> </ul>	25
Correct identification of degree of damage to the panels: <ul style="list-style-type: none"> <li>• Degree of damage to all damaged panels correctly identified, 15 pts</li> <li>• More than 50%, 7.5 pts</li> <li>• Less than 50%, 0 pts</li> </ul> Three most critical panels identified, 15 pts	30
Time to complete the survey <ul style="list-style-type: none"> <li>• Fastest, 15 pts</li> </ul>	15



<ul style="list-style-type: none"> <li>• Slowest, 0 pts</li> </ul> Others scaled appropriately	
<b>Total Possible Score</b>	<b>70</b>

## Phase 2 Task 2 and Task 3 – Detailed Inspection and Marker Placement

79. An overview of the Task requirements is in Para 34 and 41. If the three critical solar panels were not determined in Task 1, teams will be given the locations for Task 2. Teams will be scored on the criteria in Table 3:

Table 3 - Solar Panel Inspection and Marking Scoring

<b>Criteria</b>	<b>Score</b>
Damage area details correctly identified <ul style="list-style-type: none"> <li>• Type of damage identified – 5 pts each</li> </ul>	15
Damage dimensions <ul style="list-style-type: none"> <li>• Width accuracy per damage               <ul style="list-style-type: none"> <li>○ 0 pts, +/- 3.0 cm</li> <li>○ 1.25 pts, +/- 2.0 cm</li> <li>○ 2.50 pts, +/- 1.0 cm</li> </ul> </li> <li>• Height accuracy per damage               <ul style="list-style-type: none"> <li>○ 0 pts, +/- 3.0 cm</li> <li>○ 1.25 pts, +/- 2.0 cm</li> <li>○ 2.50 pts, +/- 1.0 cm</li> </ul> </li> </ul> Visual representation showing dimensional constraints provided (y/n), 10 pts	25
Placement of each marker within 30 cm of damaged area <ul style="list-style-type: none"> <li>• Touching damage area, or outside 30 cm, 0 pts</li> <li>• Placement of marker between 10 cm - 30 cm, 5 pts</li> <li>• Placement of marker within 10 cm, 10 pts</li> </ul>	30
BONUS: All three markers are delivered, and UAS returns safely to launch site	10
<b>Total Possible Score</b>	<b>80</b>

## Flight Preparation

80. Teams will be scored on their preparation for the flight window, according to the criteria in Table 4:

Table 4 - Flight Preparation Scoring

<b>Criteria</b>	<b>Score</b>
Team is on the flight line with all required equipment 30 minutes before flight window, and ready to fly at start of flight window (yes/no)	5
Team is well organized, with an obvious and effective leader and obvious tasks for team members, good cooperation between team members, good problem solving. <ul style="list-style-type: none"> <li>• All characteristics observed, 10 pts</li> <li>• Some disorganization, lack of leadership or cooperation, 5 pts</li> <li>• Disorganized, no real leader, arguing, poor problem solving, 0 pts</li> </ul>	10
UAS is designed for easy set up, with easily-assembled components, use of switches at flight line rather than connectors, logical and efficient set-up/initialization procedures, etc.	10

<ul style="list-style-type: none"> <li>• All characteristics observed, 10 pts</li> <li>• Some flaws in design for easy set up, but overall well designed, 5 pts</li> <li>• Easy set up clearly not part of the design, 0 pts</li> </ul>	
<p>Checklists are used for flight preparation:</p> <ul style="list-style-type: none"> <li>• Effective and organized use of written checklists, 5 pts</li> <li>• Ad-hoc semi-use of checklists, 2 pts</li> <li>• No checklists, 0 pts</li> </ul>	5
<b>Total Possible Score</b>	<b>30</b>

## Post-Flight Report

81. Teams must submit a report not later than 90 minutes following the close of their last flight window of the competition. The report will be scored according to the criteria in Table 5 according to how well it is written and how clearly results are presented; the accuracy of the results, which are evaluated in other criteria, will not be scored in this report.

82. The report should contain the following information at a minimum:

- a. Title page;
- b. Overview of the required Tasks;
- c. Results of each Task;
- d. Overall comments on the flights – how well things went, lessons learned, etc; and
- e. Conclusions.

Table 5 - Post Flight Report Scoring

<b>Criteria</b>	<b>Score</b>
<p>Content:</p> <ul style="list-style-type: none"> <li>• All required information is present and thoughtful comments are made about the flights, 5 pts</li> <li>• Information is missing or comments are lacking, 2 pts</li> <li>• Much information is missing or no comments, 0 pts</li> </ul>	5
<p>Presentation:</p> <ul style="list-style-type: none"> <li>• The report is well formatted, with good grammar, effective presentation of results, 5 pts</li> <li>• Some formatting or grammar issues, results presentation is not effective, 2 pts</li> <li>• Report is poorly formatted, grammar is difficult to understand, results are difficult to understand, 0 pts</li> </ul>	5
<b>Total Possible Score</b>	<b>10</b>

## Overall Phase 2 Scoring

83. To summarize the above scoring, the total score available for Phase 2 is 200 (+10 bonus), weighted as shown in Table 6:

Table 6 - Overall Phase 2 Scoring

Presentation	20
Task 1 – Solar Farm Survey	70
Task 2 – Detailed Inspection	40
Task 3 – Marker Placement	30
Flight Preparation	30
Report	10
<b>Total Possible Score</b>	<b>200</b>
Bonus for delivery of all 3 markers, return of UAS	10

## How to Maximize Your Success!

84. Winning a competition is like doing well in an exam; the results reflect the effort that was spent preparing for the event. By the time teams arrive at the competition site, development work should be complete and systems tested and backed up. The actual competition should be an extension of the ongoing proof of your system design. Teams must apply proven project management techniques and procedures that will allow them to manage both time and resources effectively. The following are comments based on experience from previous competitions; ignore them at your peril!

### Planning

85. The first and most important suggestion: **Read the CONOPS and rules!** Understand the scoring system, and understand exactly what you must accomplish and how much each Task is worth! Deliver the data or data product that is asked for! Understand and follow the timing and procedural constraints!

86. Now would be a good time to **develop a schedule with clearly identified milestones that will serve as go/no-go points.** This will allow the team to change direction before additional time and effort is expended working on a sub-optimal solution. Regularly review the schedule and adjust the time lines to reflect the effort required to develop and test potential solutions. The schedule review process is iterative. This will allow your team to assess progress throughout the design/test process so that the effort will not be concentrated at the end of the academic year when there are greater demands on the students' time.

87. **Implement a sound risk management process.** As a first step, create a risk register that will serve as a basis for the initial risk assessment. Revisit the risk analysis at each team meeting to reassess risk items and to identify new or emerging risks. Assess risks based on probability and impact and decide early whether to accept, avoid, mitigate, or transfer identified risks.
88. **Prepare yourself to respond to the many variables that could lead to an on-site system failure.** Risk management is only one part of an overall project management approach, but many of the failures observed at the competition could have been avoided had the team used a more disciplined project management approach during their system development process.

## System Design

89. **Create a design that is simple to prepare and operate.** Minimize the use of connectors, and maximize switches. Have access panels that are easy to operate...and then have them completely closed before the flight window. In previous competitions, it was amazing the total time wasted by teams either in the tent or on the runway hooking up stuff and taping panels, etc during their flight window. Make sure your design makes it easy to swap key components, like, say, batteries!
90. **Think about the flow for setting up and conducting the flight, and how your design can minimize the time required once the clock starts.** Remember that you cannot turn on any transmitters until your flight window opens – most teams appeared to be surprised by this, and didn't have processes in place to quickly get going when they could do so. You should have everything plugged in, ready to go, and tested well before your flight window, such that when your flight window opens and you're able to transmit you can quickly check to confirm things you already know were working are still working...then get airborne.
91. It is highly recommended that teams **consider including off-the-shelf components** where possible into the design. For example, teams may consider the use of an “almost ready to fly” radio controlled system as the basic airframe with custom avionics or they may choose to use a small-scale commercial autopilot in a custom designed airframe.
92. **Develop a pre-event test and practice plan based on the competition criteria.** There is no substitute for training and experience. By the time the aircraft is flown in competition, it reflects the team's readiness to provide a proven solution to a client's problem. The client wants results; it is up to the team to convince the client that their solution is able to provide quality results. Do not forget that quality can be defined as conformance to specification. Designs that attempt to “gold plate” their system inevitably generate additional risks.

## Preparation at Home

93. As the competition date approaches, conduct a risk management process specific to the venue and event. This is critical because there are certain risks—high winds, for example—that could easily make requirements other than UAS performance the deciding factor in winning the competition. Prepare contingency plans.
94. Get major issues identified and resolved long before you show up for the competition.
95. **Prepare PRINTED procedures and checklists, and PRACTICE using them.**

96. Make sure you have a leader...who can orchestrate all activities in a calm manner according to procedures you've planned...and who understands the systems and people to make calm decisions when things don't go according to plan.
97. Physically organize all required components to make assembly easy at the flight line.
98. Consider potential failure modes and crash breakage and create a 'medical kit' of extra parts and supplies to enable you to get back in the air as soon as possible.
99. Conduct extensive testing of all aircraft and other systems, including all integrated together.
100. **Practice flying your UAS in all weather/wind conditions!** One year the entire weekend had howling winds and most teams crashed at least once. Google and understand 'dynamic rollover' – in high winds you need to transition the UAS from solidly on the ground to away from the ground very quickly...and the reverse on landing.
101. Practice fixing things and swapping things, and make sure your design facilitates this. Having to remove major airframe components to swap a battery isn't a good idea!
102. **Conduct actual flight trials stimulating the entire competition from start to finish**, including set up and initiation of systems within the flight window. Make sure every member of the team knows exactly what they are supposed to do and when they're supposed to do it. Make sure the required technical and flight procedures are known by EVERY member of the team.
103. Just a suggestion. Skydivers practice 'dirt diving', where a jump is rehearsed on the ground so everyone is clear on the sequence of the formations, the grips they need to take, etc. You'll also see skydivers in the airplane with their eyes closed, mentally visualizing and rehearsing just before jumping. Use the Dirt Dive concept to prepare for the competition; even the night before or just before going to the flight line – get your whole team together and run mentally through the entire scenario from arrival at the setup site to completion of the mission, including every action that every member of the team must take, talking through it in as close to real time as possible. Do the motions with your hands and imagine what you're doing, to form a mental picture of the entire flight preparation and conduct. Time passing during the flight window is your enemy...

## Competition Preparation

104. The night before/hours before:
  - a. Check all systems on the UAS, controls systems, and telemetry.
  - b. Organize all your Stuff.
  - c. Conduct multiple Dirt Dives.

## On the Flight Line

105. Arrive on the flight line not later than 60 minutes before your flight time.
106. Set up your flight line equipment, which you already checked, right? Do you have your 'medical kit'?

107. Move the aircraft to a location where it can be immediately moved onto the field at the start of your flight window. Most teams last year did final checks in the tent and then wasted time maneuvering the UAS to the Gator and out to the field.
108. **Use your checklists to make sure everything gets done in the proper sequence!**
109. Use cables to test all telemetry/RC if possible.
110. Be ready to move to the flight line at least 10 minutes before your flight window.
111. At the start of your flight window, establishing wireless communications between components and confirmation that they all work should take no more than a minute. There should be no hooking up of connectors at this point! **If during your flight window you have to connect, assemble, close, or tape anything, you screwed up your system design or your pre-flight preparations.**

## Papers and Presentations

112. Pre-flight presentation. Remember that this presentation is intended for an audience of clients...they're not interested in a lot of technical detail, and they need to be told exactly how you're going to accomplish their mission and how you're going to meet their requirements. The presentation should not mention the competition! In essence, play the game – it's important to embrace your role as the service provider of a drone solution and pretend that you're actually conducting the briefing to a client. Make sure, however, that you fulfill all of the competition requirements for the presentation, for example, introduce your team! PowerPoint is your friend - it will help ensure you cover everything you intended to say, and make it easy for the audience to understand exactly what you're saying and how it relates to their requirements.

## Wise Words ☺

113. The weather will be different than you think. Be prepared. We were all wearing toques and multiple layers in Alma 2017, and tents were being blown over. Expect snow.
114. You need to demonstrate what your system can do without being sidelined by gotchas or mishaps.
115. Practice. You need to understand your system and your team mates.
116. Reliability is key. Predictability is almost as good.
117. Time passes during your flight window whether you're flying or not.
118. Corollary – you can't win if you don't fly. Get the thing in the air and meet at least some of the competition requirements.
119. Corollary – you have no idea how other teams will fare or how many points it'll take to win. Getting some points is a heck of a lot better than getting none.
120. Do not start uploading firmware or assembling the aircraft after the clock starts – have it ready to take to the skies!
121. Your only pre-clock constraint is radio silence. Think about how far you can prepare before radios come on. Use umbilical cables. Minutes count.

122. Checklists are key to a predictable outcome. Checklists after the clock starts must be short.
123. Team radio calls and verbal communications should be practiced when doing flights before the competition. Having standard messages will prevent confusing conversations. Dirt Dive!
124. Boring is good. Boring wins. Flashy often stays on the ground.
125. Corollary: you can win with a well-understood, low-tech approach. You won't likely win with a complex system that you haven't learned to manage.
126. RF and data link technology can be the biggest issue in the system, especially if using more than one frequency. Simple is good.
127. Did we mention: Keep it simple?
128. Test data links extensively before the competition.
129. When testing, understand that ground-to-ground range is short compared with ground-to-air.
130. Corollary 1: get your GCS antennas up high.
131. Corollary 2: don't stand in front of your team's antennas.
132. Frequencies interfere. Nearby antennas can conflict even on different frequencies.
133. Look up "RF interference". Think of it as a bad thing. Don't forget your GPS has an antenna too.
134. Watch the other teams operate. Look for ways they're being effective, and ways they're not.
135. Bring a spare. Keep software backups. Have a quick response 'medical' kit.
136. Be gentle with your wires, for they cause failure. But you've minimized connectors, right?
137. Practice more.
138. It doesn't matter how well your system works if you fail to do the stuff that scores points!
139. Winning teams are very selective in the changes they make to their system and team.
140. Good Planning and Good Luck!

## Questions from Teams

Where appropriate, the responses have been incorporated in the CONOPS, with appropriate cross-references from the questions.

**If in doubt, READ the CONOPS and understand the rules...**

Date	Question	Response
10 Sep 18	<ul style="list-style-type: none"> <li>- Which specific brand of Velcro will be used ?</li> <li>- Will the "solar panel" have the loops or hoops side of the Velcro?</li> <li>- Are we allowed to attach objects to the payload and keep them attached. Could those objects assist with adherence to the Velcro?</li> <li>- Can more than three markers be carried by the UAV in the delivery flight?</li> <li>- Are we allowed to drop and leave other objects to assist with Task 2?</li> </ul>	<p>Teams will be provided with three markers, which will include the required Velcro – the soft (loop) side will be on the target panel, and the hook side will be on the markers. The brand of Velcro <u>may</u> be released later, but this won't be the determining factor in whether your solution works!</p> <p>The three provided markers must be transported on a single flight to be placed on the targets; no other markers may be used. The markers may not have anything attached to them, must be attached to the targets using the included Velcro only, and no other objects may be left on the target or ground.</p> <p>To be scored, the markers must be oriented with the Velcro side latched onto the target (eg, the markers cannot just be lying on their side on the panel).</p>
28 Sep 18	<ol style="list-style-type: none"> <li>1. What are the dimensions of the solar panels?</li> <li>2. Are teams permitted to land on the solar panels?</li> <li>3. What brand of velcro is present on the surface of the solar panels?</li> <li>4. What material is the surface of the solar panels?</li> <li>5. Are solar panels at the solar farm raised up off of the ground or tilted up on the ground? (Ideal ramp for a ground vehicle?)</li> </ol>	<ol style="list-style-type: none"> <li>1. Details of the solar panel size, configuration, and layout will be available in the map given to teams at the competition (Para 27.d).</li> <li>2. The UAS may not land on the panels. Incidental contact between UAS and panel will not be penalized; however, the methodology of locating and placing the markers may not require contact.</li> <li>3. See Sep 10 answers.</li> <li>4. Specific material to be determined, will be reflective.</li> <li>5. For Task 2 and 3 the three solar panels will not rest on the ground, eg, not an 'ideal ramp for a ground vehicle'.</li> </ol>



	<p>6. What are the conditions of the ground surrounding the solar panels? (grass, dirt, gravel?)</p> <p>7. Are teams permitted to drive on the ground?</p> <p>8. Are teams permitted to deploy and retrieve a tethered or untethered ground vehicle system from an air vehicle?</p> <p>9. Are the bonus points for returning without markers awarded if markers are deployed at random?</p> <p>10. Are teams given more than three markers? Can we bring or use more?</p> <p>11. Are teams permitted to modify markers? i.e. add aerodynamic structures, pinholes, etc?</p> <p>12. Are teams permitted to leave objects/consumables in the solar farm?</p> <p>13. What is the layout of the solar farm before the storm? i.e. the formation of solar panels, grid, circle, random?</p> <p>14. When given the location of the solar farm, are teams given a point coordinate or an area indicating perimeter?</p> <p>15. Would it be possible for USC to provide teams with a schematic for the IR beacon for replication and testing purposes?</p> <p>16. How is the IR used to track damage? Number of IR beacons? Power level?</p>	<p>6. To be determined and will vary between panel locations depending on the ground conditions in the solar farm area, and on the recent weather.</p> <p>7. Fill your boots. You might want to think carefully about the suitability of this as a methodology.</p> <p>8. See answer above.</p> <p>9. Of course not. Read the Conops more carefully ☺.</p> <p>10. No. See 10 Sep response.</p> <p>11. No, see 10 Sep</p> <p>12. No, see 10 Sep</p> <p>13. Per map to be given to you at the competition.</p> <p>14. You will be given the perimeter of the solar farm.</p> <p>15. You will be provided with the IR wavelength range of the emitters so you can make sure your detector is suitable.</p> <p>16. You will be given this information in the briefing prior to the flights.</p>
--	--	---

ALL DIMENSIONS  
ARE IN mm

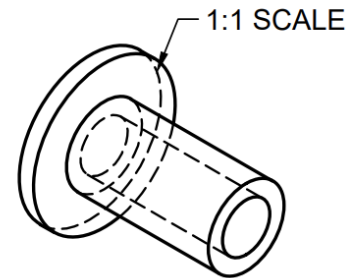
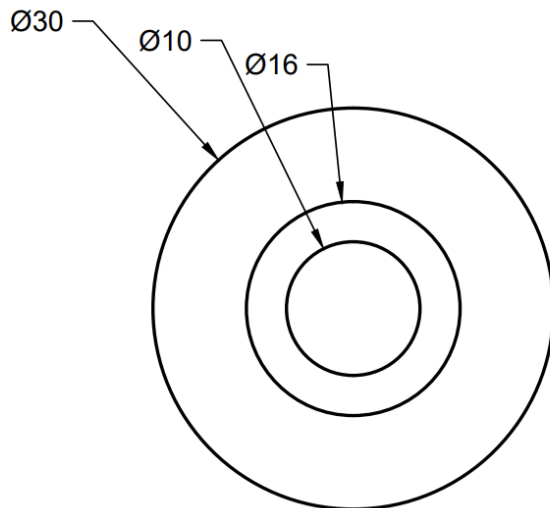
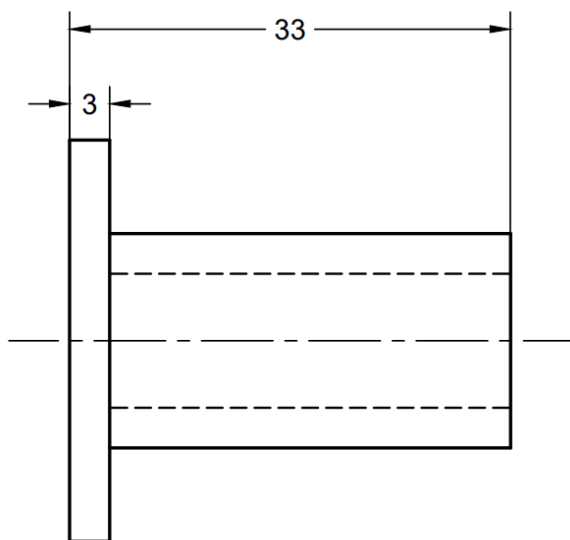

	PROJECT			REV
	2019 USC Student Competition			
	TITLE			
	Solar Panel Marker			
APPROVED	SIZE	CODE	MATERIAL	
CHECKED			PLA (Polylactic Acid)	
DRAWN Zachary Guy 09/04/2018	SCALE 2:1	WEIGHT 7.8 g	SHEET	